



**SPIRITS
COLLECTION**



WHISKIES

A range of designs to help you highlight the unique character of your product.



FLINT
F3016905

100CL SPIRITUOSEN

AVAILABLE COLORS



Flint

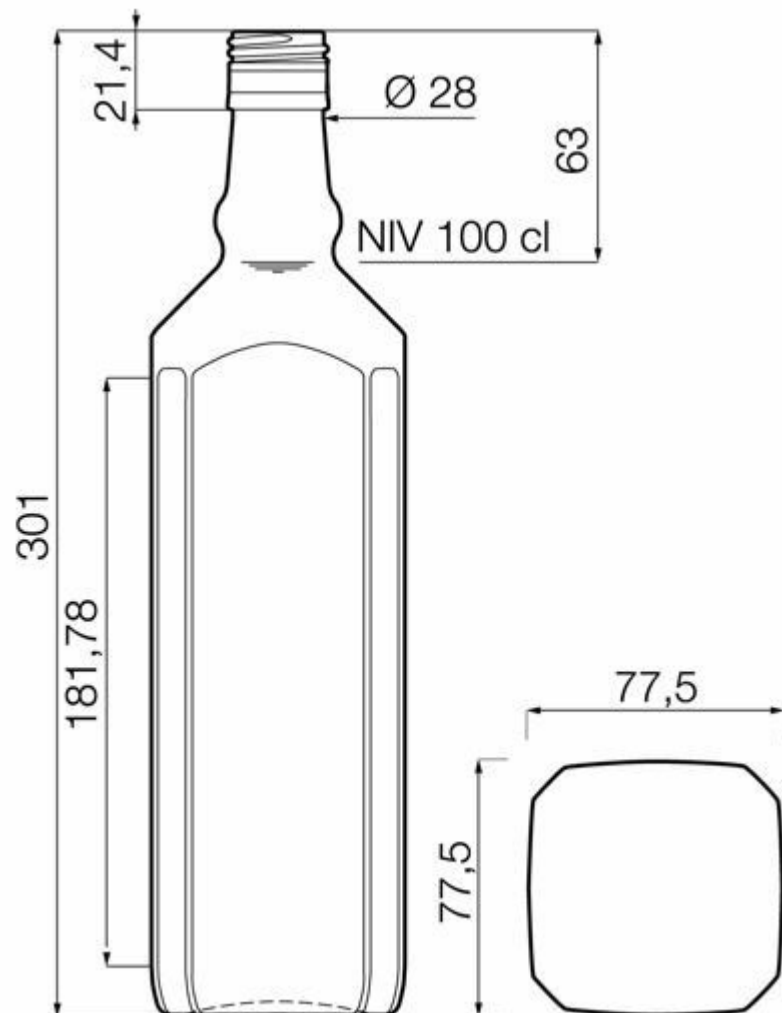

TECHNICAL SPECIFICATIONS

Product code	016905
Capacity	100.0 cl
Brimfull capacity	103.0 cl
Height	301.0 mm
Diameter	77.5 mm
Shape	Engraved round
Finish	Screw
Label protection	No
Refillable	No
Weight	580 g
Country	Germany

PACKAGING SPECIFICATIONS

Containers per pallet	1080
Layers per pallet	6
Pallet width	1000 mm
Pallet depth	1200 mm
Pallet height	1986 mm
Gross weight of pallet	660.00 kg

i Other packaging specs are available upon request.



O-I Europe - 31 March 2025

The images, specifications and other data on this page are for information purposes only. The present information can in no way be used or interpreted as a technical drawing. Specific advice should be obtained from your O-I representative with regards to the suitability of products prior to any application. The information on industry containers is updated from time to time, however O-I reserves the right to amend the specifications or to withdraw certain containers from sale without notice.

www.o-i.com

www.glass-catalog.com

© 2025, O-I Glass, Inc